

Product Specification

PRODUCT NUMBER	82-060-00
DESCRIPTION	7" 1280x800 SFTTFT, HDMI, USB PCT

<p>Approved: Product Manager</p>  <p>05/05/2020</p> <hr/> <p>Signature Date</p>	<p>Approved: Doc Control</p>  <p>05/05/2020</p> <hr/> <p>Signature Date</p>
--	---

REVISION HISTORY

Version	Date	Section	Comments
REV 00	12/18/2017	All	Tentative Specification first issued.
REV 01	12/29/2017	1.4, 3.1, 4.1, 5.2, 7.2	Panel Specs, Dimensions, Operating Temp, Drawing,
REV 03	12/30/2017	5.2	Add ESD Tape to assembly
REV 04	02/01/2018	2.0, 5.2	Increase Depth to accommodate 5V Barrel Connector, Update drawing for new architecture and interim USB Daughter PCBA and interim 5V barrel Connector.
REV 05	02/07/2018	5.1, 5.2	Add Exploded Image, Relocate USB Daughter PCB
REV 06	02/18/2018	5.2, 6.1	Consolidate USB Daughter PCBA into PCT Controller, Change 5V Connector
REV 07	03/05/2018	5.2, 9, 10	Add UL material declaration, Add FCC declaration, Add standoff dimensions to 2D Drawings
REV 08	10/18/2018	5.2	Add 2mm corner radius to touch screen drawing, replace IPS with SFT
REV 09	3/25/2019	6.4	Remove connector second source
REV 10	04/30/2020	5	Update Drawings
REV 11	05/05/2020	5.2, 7.2	Add Image, remove chromaticity values, update backlight lifetime to 30K hours

TABLE of CONTENTS

1. GENERAL DESCRIPTION	5
1.1 OVERVIEW	5
1.2 FEATURES	5
1.3 APPLICATION	5
1.4 GENERAL PANELSPECIFICATIONS	5
2. MECHANICAL SPECIFICATIONS.....	5
3. ABSOLUTE MAXIMUM RATINGS.....	6
3.1 ABSOLUTE RATINGS OF ENVIRONMENT	6
5. MECHANICAL CHARACTERISTICS.....	6
5.1 SLDPRT Model.....	6
5.2 IMAGE.....	6
5.3 EXPLODED DRAWING.....	7
5.4 DRAWING	8
6. CONNECTORS.....	9
6.1 J1 – POWER.....	9
6.2 J2 – USB TOUCH – MINI.....	9
6.3 J3 – HDMI A.....	9
6.4 J4 – PWM	9
7. OPTICAL CHARACTERISTICS.....	10
7.1 TEST CONDITIONS	10
8. ENVIRONMENTAL / RELIABILITY TEST CRITERIA	13
9. FCC DECLARATION.....	14
10. UL MATERIAL DECLARATION.....	14

11.	PRECAUTIONS.....	14
11.1	ASSEMBLY AND HANDLING PRECAUTIONS.....	14
11.2	SAFETY PRECAUTIONS.....	14

1. GENERAL DESCRIPTION

1.1 OVERVIEW

82-060-00 is a 7.0" SFTTFT module with LED Backlight, HDMI display interface and a USB PCT touch interface. This module supports 1280x800 WSVGA mode.

1.2 FEATURES

- WSVGA (1280 x 800 pixels) resolution
- HDMI Display Interface
- Glass-Glass USB HID Compliant Projected Capacitive Touch Interface.
- Wide operating temperature.
- Single 5 Volt Operation
- Industrial mounting via ABS carrier and 3M VHB gasket.
- "Industrial by Design" Long Product Availability.
- RoHS compliance
- SOLIDWORKS® model available with PixelNext NDA on file.

1.3 APPLICATION

- Medical Displays, Marine, Instrument, Point of Sale, Broadcast, Audio, Factory HMI, etc.

1.4 GENERAL PANEL SPECIFICATIONS

Item	Specification	Unit	Note
Active Area	149.76 (H) x 93.60 (V) (7.0" diagonal)	mm	(1)
Bezel Opening Area	150.76 (H) x 94.60 (V)	mm	
Technology Type	SFTTFT	-	-
Pixel Number	1280 x 800	pixel	-
Pixel Pitch	0.117 (H) x 0.117 (V)	mm	-
Pixel Arrangement	RGB vertical Stripe	-	-
Display Colors	16,194,277 / 262,144	color	-
Display Mode	Normally Black	-	-
Surface Treatment	(7H), Glare	-	-
Module Power Consumption	TBD	W	Typical

2. MECHANICAL SPECIFICATIONS

Item	Typ.	Unit	Note
Module Size	Horizontal(H)	180.44	(1)
	Vertical(V)	125.86	
	Depth(D)	24.25	
Weight	TBD	g	

Note (1) Please refer to the attached drawings for more information of front and back outline dimensions.

3. ABSOLUTE MAXIMUM RATINGS

3.1 ABSOLUTE RATINGS OF ENVIRONMENT

Item	Symbol	Value		Unit	Note
		Min.	Max.		
Power Input Voltage	V _{CC}	4.85	5.15	V _{DC}	at 25 ± 5°C
Operating Ambient Temperature	T _{OP}	-20	+70	°C	
Storage Temperature	T _{ST}	-30	+80	°C	

Notes:

1. The response time will become lower when operated at low temperature.
2. Background color changes slightly depending on ambient temperature. The phenomenon is reversible.
3. Ta ≤ 40°C: 85% RH MAX Ta ≥ 40°C:
4. Absolute humidity must be lower than the humidity of 85% at 40°C.
5. Maximum wet-bulb temperature is 46°C.
6. Condensation of dew must be avoided as electrical current leaks will occur, causing degradation of performance specifications

5. MECHANICAL CHARACTERISTICS

5.1 SLDPRT Model

Available upon request. Contact Factory

5.2 IMAGE

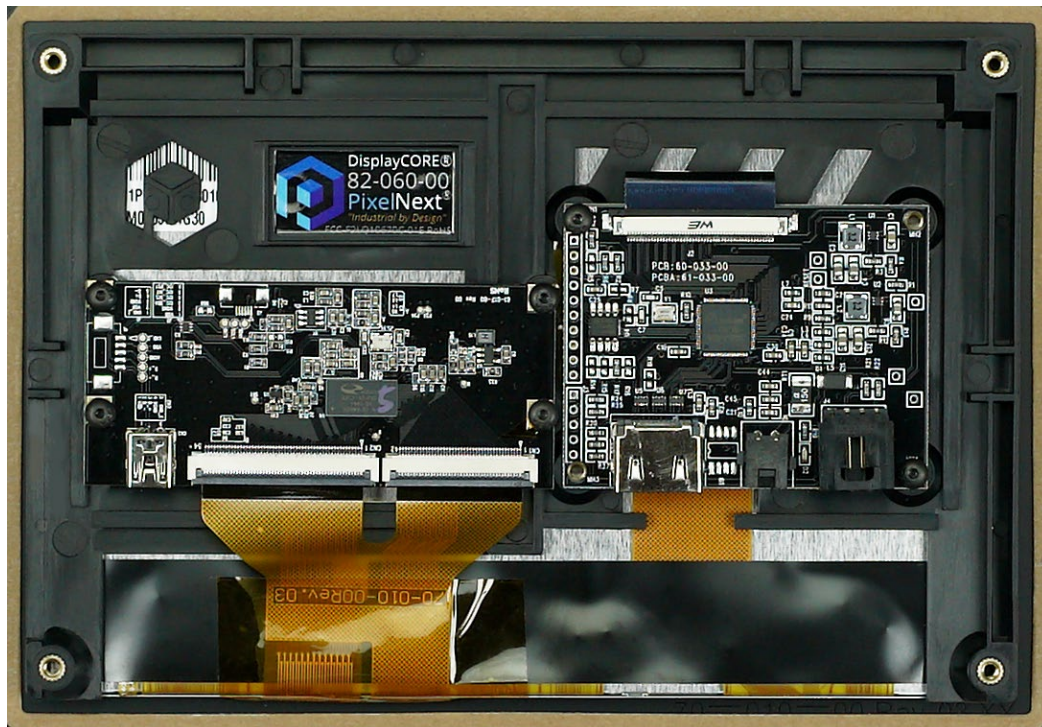

5.3 EXPLODED DRAWING

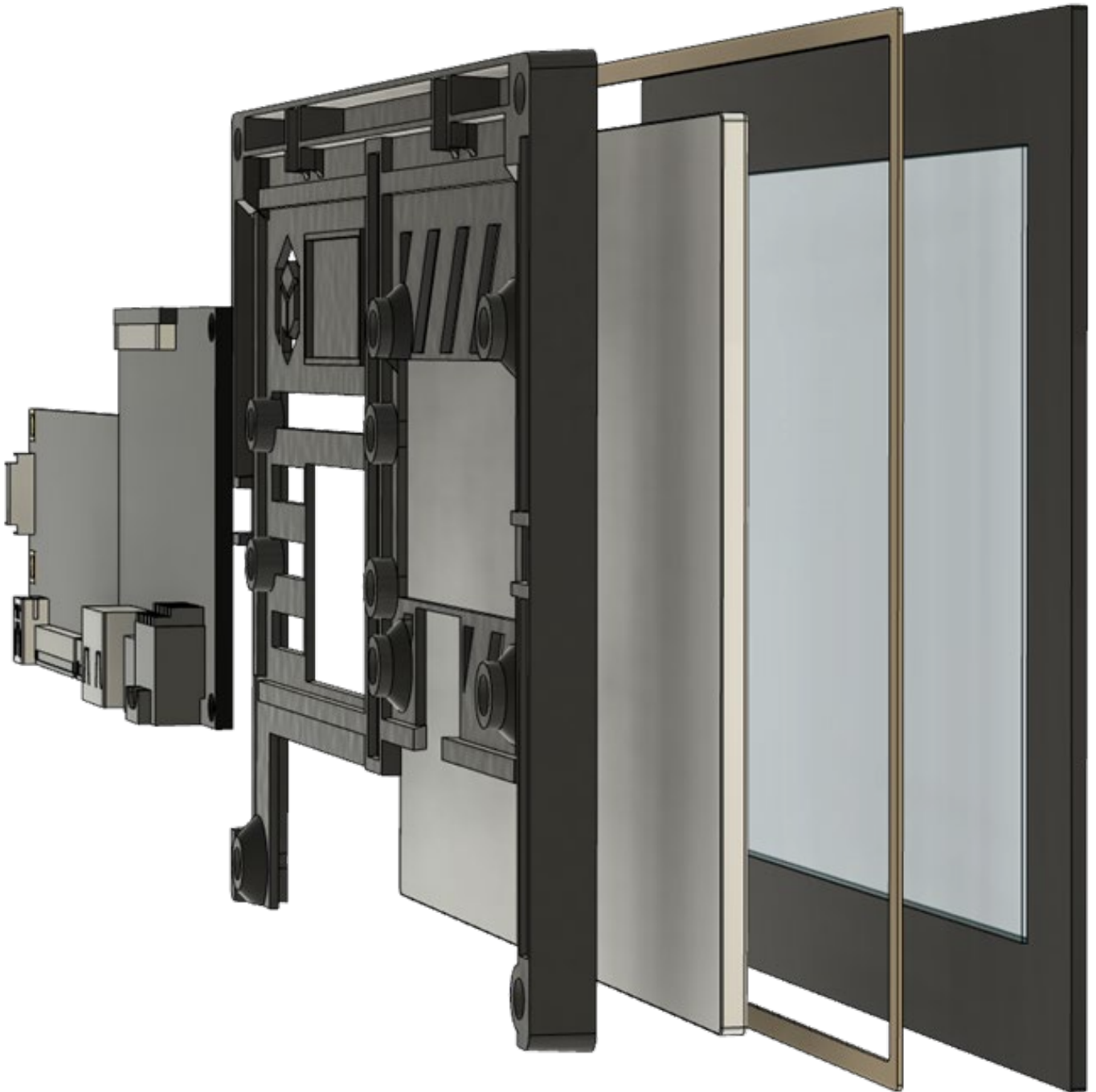

5.4 DRAWING

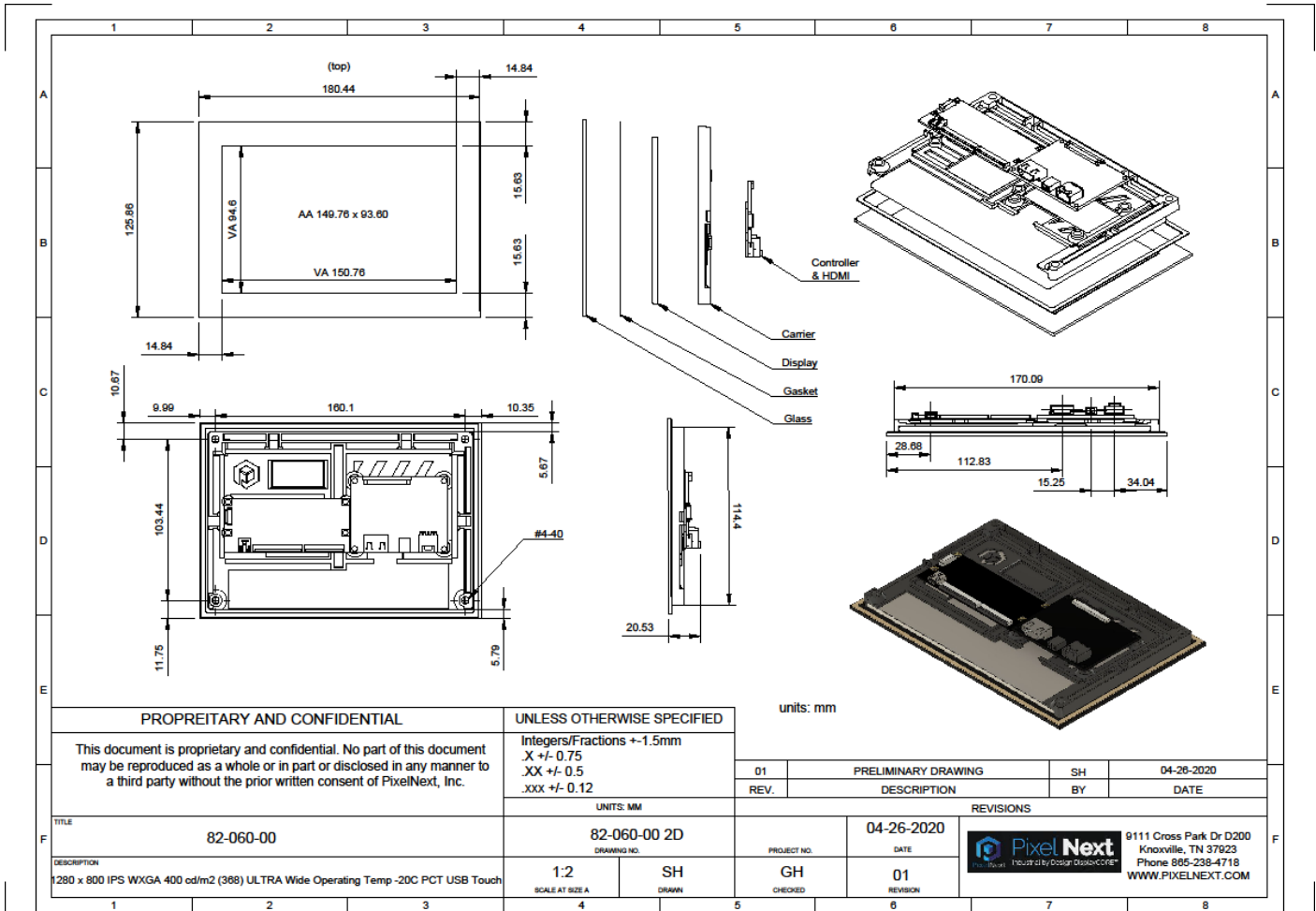

6. CONNECTORS

6.1 J1 – POWER

Pin	Name	Description
1	5V	Power – (Rated at 5V DC 2A)
1	GND	Ground

TE Connectivity 5V Connector - 2-1445098-2

6.2 J2 – USB TOUCH – MINI

Pin	Name	Description
1	5V	5V (sourced from USB 2.0 host) Used only to power PCT Touch IC
2	D-	Data differential pair minus
3	D+	Data differential pair plus
4	ID	ID (Host or Slave)
5	GND	Ground

6.3 J3 – HDMI A

Pin	Name	Description
1	TMDS Data2+	Digital Input Channel 2 True
2	TMDS Data2 Shield	Ground
3	TMDS Data2-	Digital Input Channel 2 Complement
4	TMDS Data1+	Digital Input Channel 1 True
5	TMDS Data1 Shield	Ground
6	TMDS Data1-	Digital Input Channel 1 Complement
7	TMDS Data0+	Digital Input Channel 0 True
8	TMDS Data0 Shield	Ground
9	TMDS Data0-	Digital Input Channel 0 Complement
10	TMDS Clock+	
11	TMDS Clock Shield	Ground
12	TMDS Clock-	
13	CEC	Control
14	Reserved/HEC Data-	No Connection
15	SCL	DDC clock
16	SDA	DDC data
17	DDC/HEC/CEC Ground	Ground
18	+5 V Power	power EDID/DDC
19	Hot Plug Detect/HEC Data+	

6.4 J4 – PWM

Pin	Name	Description
1	N/C	
2	LCD_PWM	PWM Signal 100 KHz Maximum (50Khz Recommended)
3	GND	Ground
4	N/C	

TE CONNECTIVITY 2-1445098-4

7. OPTICAL CHARACTERISTICS

7.1 TEST CONDITIONS

Item	Symbol	Value	Un
Ambient Temperature	Ta	25±2	°C
Ambient Humidity	Ha	50±10	%
Converter Voltage	V _i	12	V
Converter Duty		100%	

7.2 OPTICAL SPECIFICATIONS

Item	Symbol	Condition	Min	Typ	Max	Unit	Remark
Contrast Ratio	CR	$\Theta=0^\circ$	600	800	–		Note 8
Response Time	Tr(on)+Tf(off)	25°C	–	35	40	ms	Note1,5
Viewing Angles	ΘT	CR≥10	70	80	–	Degree	Note 2
	ΘB		70	80	–		
	ΘL		70	80	–		
	ΘR		70	80	–		
Luminance	L		–	400	–	cd/m ²	Note 1,6
Uniformity	U		75	75	–	%	Note 1,7
Lifetime			–	30,000	–	Hours	Note 9

Test Conditions:

1. IF= 20mA (one channel), the ambient temperature is 25°C.
2. The test systems refer to Note 1 and Note 2.

Note 1: Definition of optical measurement system.

The optical characteristics should be measured in dark room. After 10 Minutes operation, the optical properties are measured at the center point of the LCD screen. All input terminals LCD panel must be ground when measuring the center area of the panel.

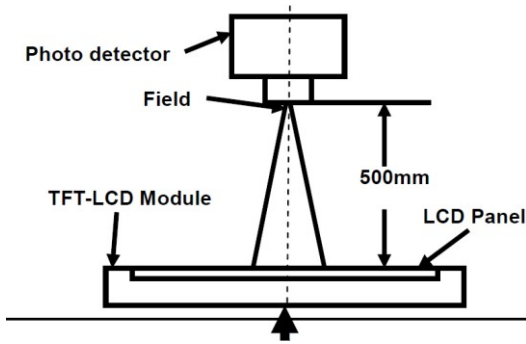

Item	Photo Detector	Field
Contrast Ratio	SR-3A	1°
Contrast Ratio		
Contrast Ratio		
Contrast Ratio		
Contrast Ratio	BM-7A	2°

Note 2: Definition of viewing angle range and measurement system.

viewing angle is measured at the center point of the LCD by CONOSCOPE(ergo-80)

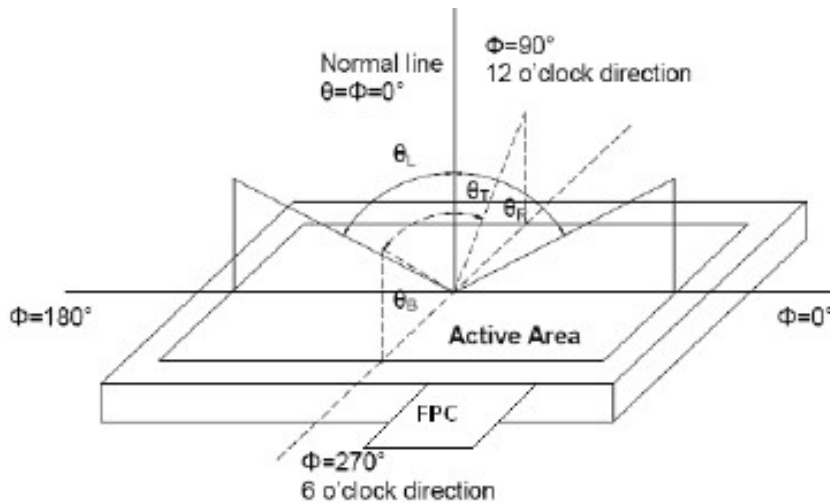

Note 3: Definition of contrast ratio

Contrast Ratio (CR)= Luminance measured when LCD is on “White” state/Luminance measured when LCD is on “Black” state

“White state “: The state is that the LCD should be driven by V_{white} (V_{white} : To be determined). “Black state: The state is that the LCD should be driven by V_{black} (V_{black} : To be determined).

The response time is defined as the LCD optical switching time interval between “White” state and “Black” state. Rise time (T_{ON}) is the time between photo detector output intensity changed from 90% to 10%. And fall time (T_{OFF}) is the time between photo detector output intensity changed from 10% to 90%.

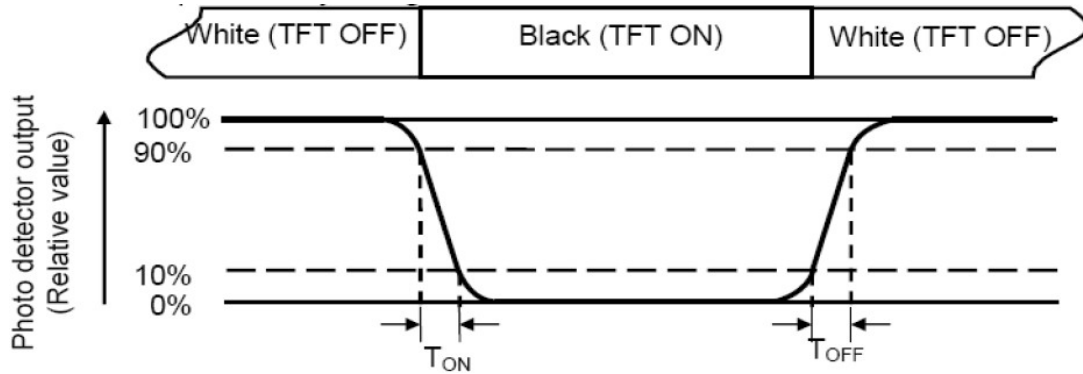

Note 5: Definition of color chromaticity (CIE1931) Color coordinates measured at center point of LCD.

Note 6: Definition of Luminance Uniformity

Active area is divided into 9 measuring areas. Every measuring point is placed at the center of each measuring area. L_{max} : The measured Maximum luminance of all measurement position. L_{min} : The measured Minimum luminance of all.

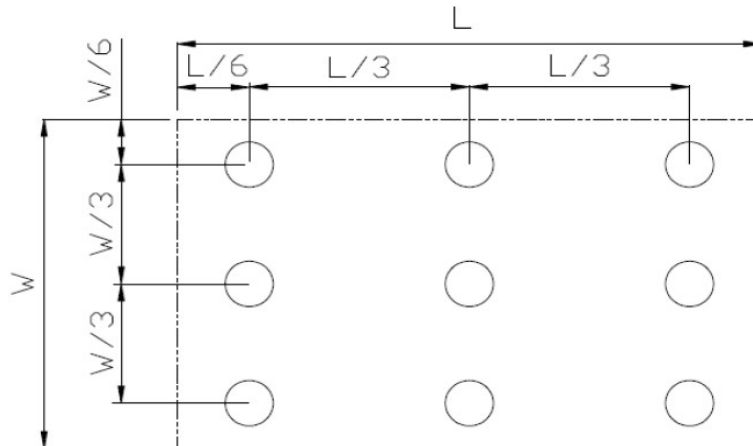

Note 7: Definition of Response time

Note 8: Definition of Luminance: Measure the luminance of white state at center point. Left/right 0° Top/bottom 5°

Note 9: If LED is driven by high current, high ambient temperature & humidity condition. The life time of LED will be reduced. Operating life means brightness goes down to 50% initial brightness. Typical operating life time is estimated data.

8. Environmental / RELIABILITY TEST CRITERIA

No	Test Item	Condition	Judgment criteria
1	High Temp Operation	Ts=+70°C, 96hrs	Per table in below
2	Low Temp Operation	Ta=-20°C, 96hrs	Per table in below
3	High Temp Storage	Ta=+80°C, 96hrs	Per table in below
4	Low Temp Storage	Ta=-30°C, 96hrs	Per table in below
5	High Temp & High Humidity Storage	Ta=+60°C, 90% RH 96 hours	Per table in below (polarizer discoloration is excluded)
6	Thermal Shock (Non-operation)	-30°C 30 min~+80°C 30 min, Change time:5min, 5Cycles	Per table in below
7	ESD (Operation)	Air discharge:+/-8KV, Contact discharge:4KV	Per table in below
8	Vibration (Non-operation)	10Hz~150Hz, 100m/s ² , 120min	Per table in below
9	Shock (Non-operation)	Half- sine wave,300m/s ² ,11ms	Per table in below
10	Package Drop Test	Height:80 cm, 1 corner, 3 edges, 6 surfaces	Per table in below

INSPECTION	CRITERION(after test)
Appearance	No Crack on the FPC, on the LCD Panel
Alignment of LCD Panel	No Bubbles in the LCD Panel No other Defects of Alignment in Active area
Electrical current	Within device specifications
Function / Display	No Broken Circuit, No Short Circuit or No Black line No Other Defects of Display

9. FCC Declaration

In Compliance: EMC Certificate of Test F2LQ10670C-01E.
FCC CFR 47, Part 15, subpart B:2017, Class A.
Complete test report available under NDA.

10. UL Material Declaration

- (1) 80-025-00 LVDS Display Manufacturer, Tianma (UL-NWQG2.E333987) TM070JDHG30-00
- (2) 70-010-00 PCT Touch Screen – Inert Borosilicate Glass – Manufacturer Beijing Jinke Xingtai Co. Ltd
- (3) 90-029-00 Module Carrier – Firewire® FR-ABS is made using a premium UL94 V-0 rated ABS.
- (4) 61-017-00 HDMI to LVDS Controller PCBA – Manufacturer Shenzhen Jinjiaxing Electronic CO LTD. UL Certificate E353925
- (5) 61-016-00 DSI to LVDS Transition PCBA – Manufacturer Shenzhen Jinjiaxing Electronic CO LTD. UL Certificate E353925
- (6) 20-001-01, 20-002-01 Gaskets – 3M VHB RP25 - UL746C

11. PRECAUTIONS

11.1 ASSEMBLY AND HANDLING PRECAUTIONS

- (1) Do not apply rough force such as bending or twisting to the module during assembly.
- (2) To assemble or install module into user's system can be only in clean working areas.
The dust and oil may cause electrical short or worsen the polarizer.
- (3) It's not permitted to have pressure or impulse on the module because the LCD panel and Backlight will be damaged.
- (4) Always follow the correct power sequence when LCD module is connecting and operating. This can prevent damage to the CMOS LSI chSFTduringlatch-up.
(5) Do not pull the I/F connector in or out while the module is operating.
(6) Do not disassemble the module.
- (7) Use a soft dry cloth without chemicals for cleaning, because the surface of polarizer is very soft and easily scratched.
- (8) It is dangerous that moisture come into or contacted the LCD module, because moisture may damage LCD module when it is operating.
- (9) High temperature or humidity may reduce the performance of module. Please store LCD module within the specified storage conditions.
- (10) When ambient temperature is lower than 10°C may reduce the display quality.
For example, the response time will become slow.
- (11) Do not keep same pattern in a long period of time. It may cause image sticking on LCD.

11.2 SAFETY PRECAUTIONS

- (1) Do not disassemble the module or touch the backlight array.
- (2) If the liquid crystal material leaks from the panel, it should be kept away from the eyes or

mouth. In case of contact with hands, skin or clothes, it has to be washed away
thoroughly with soap.

(3) After the module's end of life, it is not harmful in case of normal operation and storage.